

**SCIENCE**

Paper &amp; Solution

SET-1

Time: 3 Hrs.

Max. Marks: 90

**General Instructions:**

1. The question paper comprises **two** Sections, **A and B**. You are to attempt both the sections.
2. There is no overall choice. However, internal choice has been provided in all the five questions of five marks category. Only one option in such question is to be attempted.
3. All questions of **Section-A** and **Section-B** are to be attempted separately.
4. Question numbers **1 to 3** in Section A are one-mark questions. These are to be answered in one word or in one sentence.
5. Question numbers **4 to 7** in Section A are two marks questions, to be answered in about 30 words each.
6. Question numbers **8 to 19** in Section A are three marks questions, to be answered in about 50 words each.
7. Question numbers **20 to 24** in Section A are five marks questions, to be answered in about 70 words each.
8. Question numbers **25 to 42** in Section B are multiple choice questions based on practical skills. Each question is a one-mark question. You are to select one most appropriate response out of the four provided to you.

**SECTION A**

**Question 1.** How many horizontal rows are there in the modern periodic table and what are they called?

**Solution:** There are 7 horizontal rows in the modern periodic table. They are called periods.

**Marks: 1**

**Question 2.** List any two factors that could lead to speciation.

**Solution:** Geographical isolation and genetic drift could lead to speciation.

**Marks: 1**

**Question 3.** Mention one negative effect of our affluent life style on the environment.

**Solution:** Exploitation and overconsumption of natural resources will ultimately result in their scarcity.

**Marks: 1**

**Question 4.** Mention two functions of the human testis.

**Solution:** (a) They produce male germ cells i.e., sperms.

(b) They act as endocrine glands and secrete the hormone testosterone which controls secondary sexual characters in males.

**Marks: 2**

**Question 5.** Every one of us can do something to reduce our consumption of various natural resources. List four such activities based on the 3-R approach.

**Solution:** (a) Use of materials such as paper should be preferred as they can be reused and recycled.

(b) Materials like glass and some plastics can be recycled on heating and get easily converted into different products like toys, containers which can be reused again.

(c) e-wastes such as unused computers, mobiles etc. can be repaired and used again.

(d) Household wastes such as vegetable wastes etc. can be used as manure for plants.

**Marks: 2**

**Question 6.** 'A ray of light incident on a rectangular glass slab immersed in any medium emerges parallel to itself.' Draw a labelled ray diagram to justify the statement.

**Solution:** When a ray of light is incident on a rectangular glass slab immersed in a medium, the emergent ray comes out parallel to the incident ray. The path of the light ray is as shown:

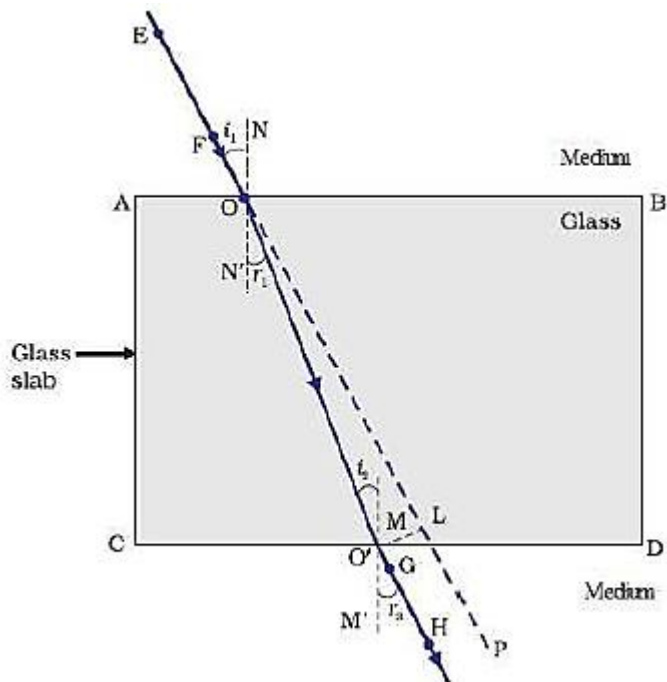

EF is the incident ray and GH is the emergent ray which is parallel to the incident ray.

**Marks: 2**

**Question 7.** We often observe domestic waste decomposing in the bylanes of residential colonies. Suggest ways to make people realise that the improper disposal of waste is harmful to the environment.

**Solution:** Some of ways to make people realise that the improper disposal of waste is harmful to the environment are:

- Improper disposal of waste will serve as a breeding ground for mosquitoes and will create favourable conditions for the spread of various diseases.
- Improper disposal of waste will release harmful gases in the environment which makes the environment unclean and unhygienic for normal living of organisms.
- The waste will flow to water bodies along with the rain water and become a threat to aquatic organisms.

**Marks: 2**

**Question 8.** Name the oxidising agent used for the conversion of ethanol to ethanoic acid. Distinguish between ethanol and ethanoic acid on the basis of (i) litmus test, (ii) reaction with sodium carbonate.

**Solution:** Alkaline potassium permanganate ( $\text{KMnO}_4$ ) or acidified potassium dichromate ( $\text{K}_2\text{Cr}_2\text{O}_7$ ) can be used as an oxidising agent for conversion of ethanol to ethanoic acid.

i. Litmus test: Ethanoic acid turns blue litmus solution red whereas ethanol being neutral in nature has no effect on litmus solution.

ii. Reaction with sodium carbonate: Ethanoic acid reacts with sodium carbonate to form sodium ethanoate and carbon dioxide gas is evolved.

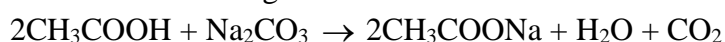

Ethanol does not react with sodium carbonate.



**Marks: 3**

**Question 9.** (a) Differentiate between alkanes and alkenes. Name and draw the structure of one member of each.

(b) Alkanes generally burn with clean flame. Why?

**Solution:** (a) Alkanes: Hydrocarbons in which the carbon atoms are joined by single covalent bonds are called Alkanes. They have general formula  $C_nH_{2n+2}$ , where n is the number of carbon atoms. Suffix, -ane is used while naming alkanes.

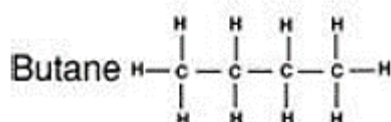
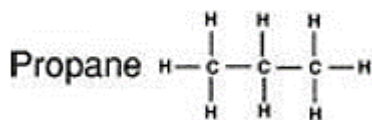
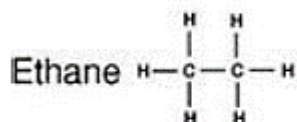
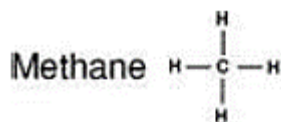

Alkenes: Hydrocarbons in which the carbon atoms are joined by a double bond are called Alkenes. They have general formula  $C_nH_{2n}$ , where n is the number of carbon atoms. Suffix, -ene is used while naming alkenes.

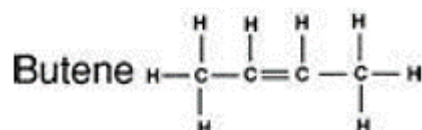
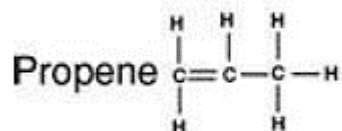
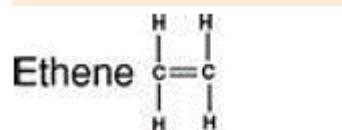

(b) Alkanes generally burn with clean flame because in them, the percentage of carbon is comparatively low as compared to other unsaturated hydrocarbons. Hence they get oxidised completely by the oxygen present in air.

**Marks: 3**

**Question 10.** Given below are some elements of the modern periodic table:

${}_4\text{Be}$ ,  ${}_{26}\text{Fe}$ ,  ${}_{14}\text{Si}$ ,  ${}_{19}\text{K}$ ,  ${}_{20}\text{Ca}$

- Select the element that has one electron in the outermost shell and write its electronic configuration.
- Select two elements that belong to the same group. Give reasons for your answer.
- Select two elements that belong to the same period. Which one of the two has bigger atomic size?

**Solution:** i.  ${}_{19}\text{K}$  has one electron in the outermost shell and its electronic configuration is 2, 8, 8, 1.

ii.  ${}_4\text{Be}$  and  ${}_{20}\text{Ca}$  belongs to same group i.e., Group 2.

Electronic configuration:

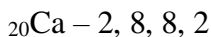
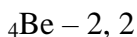

${}_4\text{Be}$  and  ${}_{20}\text{Ca}$  have same number of valence electrons in outermost shell i.e., 2 so they belong to same group.

iii.  ${}_9\text{F}$  and  ${}_4\text{Be}$  belongs to the same period i.e., period 2.

Electronic configuration:

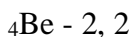
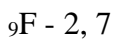

${}_4\text{Be}$  has a bigger atomic size than  ${}_9\text{F}$  because the atomic radius decreases as we move from left to right in a period due to increase in nuclear charge which tends to pull the electrons closer to the nucleus and hence size of atom reduces.

**Marks: 3**

**Question 11.** An element X (atomic number 17) reacts with an element Y (atomic number 20) to form a compound.

(a) Write the position of these elements in the modern periodic table.

(b) Write the formula of the compound formed.

Justify your answer in each case.

**Solution:** (a) Element X (atomic number 17)

Electronic configuration of X: 2, 8, 7

No. of electrons in outermost shell = 7

So, Group number = 17

No. of shells = 3

So, Period to which the element belongs = 3

Element Y (atomic number 20)

Electronic configuration of Y: 2, 8, 8, 2

No. of electrons in outermost shell = 2

So, Group number = 2

No. of shells = 4

So, Period to which the element belongs = 4

(b) X has 7 valence electrons so, it needs 1 electron to complete its octet and Y has 2 valence electrons so, it can donate its 2 electrons to acquire the octet configuration. Hence, X will gain 1 electron and Y will lose 2 electrons, so the chemical reaction is:

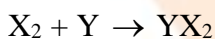

X = Cl (At. No. = 17) and Y = Ca (At. No. = 20)



**Marks: 3**

**Question 12.** 'The sex of a newborn child is a matter of chance and none of the parents may be considered responsible for it.' Justify this statement with the help of flow chart showing determination of sex of a newborn.

**Solution:** In human beings, females have two X chromosomes and males have one X and one Y chromosome. Therefore, the females are represented as XX and males as XY. At the time of mating, large number of sperms are ejaculated from the male reproductive organ (penis), into the female reproductive organ i.e., vagina. They travel towards the fallopian tubes, where only one sperm meets with the egg.

The process of fusion of the sperm and ovum is called fertilisation. The sperm has either X or Y chromosome and egg has only X chromosome. So, if a sperm carrying Y chromosome fuses with the egg, the newly born child will be male and if a sperm carrying X chromosome fuses with the egg, the newly born child will be female. There is an equal chance of fusion of either X or Y chromosome with the egg so we can say that the sex of a new born child is a matter of chance and none of the parent is responsible for it. Sex determination in humans is shown below:

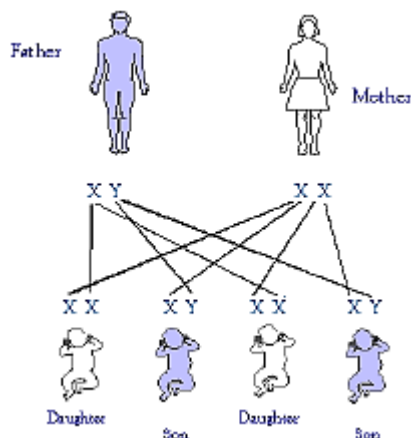

**Marks: 3**

**Question 13.** Tabulate two distinguishing features between acquired traits and inherited traits with one example of each.

**Solution:**

Acquired traits	Inherited traits
i. The acquired traits are the traits which are experienced by an individual during his life time.	i. Inherited traits are the characteristics which one acquires from his/ her ancestors.
ii. These involve changes in non-reproductive tissues (or somatic cells), which cannot be passed on to the germ cells or progeny.	ii. These involve changes in the DNA. Hence, they are transmitted to the progeny.
iii. Example- cut-tail of mice, learning to dance etc.	iii. Example- height, eye colour, skin color etc.

**Marks: 3**

**Question 14.** Write two examples each of sexually transmitted diseases caused by (i) virus, (ii) bacteria. Explain how the transmission of such diseases can be prevented?

**Solution:** Sexually transmitted diseases by virus:

Genital Herpes is caused by the Herpes Simplex virus and AIDS is caused by HIV.

Sexually transmitted diseases by bacteria:

Gonorrhoea is caused by *Nisseria gonorrhoeae* and Syphilis is caused by *Treponema pallidum*.

Prevention of transmission of STD's:

- Having sex with infected or any unknown person should be avoided.
- Sharing of needles, syringes etc. must be prohibited.
- The surgical and dental instruments should be sterilised properly before use.
- Avoid blood transfusions from infected person. Blood should be tested before transfusion.
- Adequate medical treatment should be provided to the pregnant woman to protect the child from getting infected.

**Marks: 3**

**Question 15.** (a) Explain the process of regeneration in Planaria.

(b) How is regeneration different from reproduction?

**Solution:** (a) Regeneration in Planaria:

In Planaria, any part of the body which gets cut is capable of regeneration or developing into a complete organism. Regeneration is carried out by specialized cells which proliferate and make large numbers of cells. From these mass of cells, different cells undergo changes to become various cell types and tissues. These changes take place in an organised sequence referred to as development.

(b)

Regeneration	Reproduction
1. It is a type of asexual mode of reproduction in which only single parent is involved.	1. It includes both sexual and asexual mode of reproduction in which either single parent or both the parents are involved respectively.
2. This mode of reproduction is dependent on a cut in an organism.	2. This mode of reproduction is independent of cut in an organism.
Example - Planaria.	Example - Sexual reproduction in humans.

**Marks: 3**

**Question 16.** An object of height 5 cm is placed perpendicular to the principal axis of a concave lens of focal length 10 cm. Use lens formula to determine the position, size and nature of the image, if the distance of the object from the lens is 20 cm.

**Solution:** Given that:

The height of the object  $h_o = 5$  cm

Focal length of the lens =  $-10$  cm

Object distance,  $u = -20$  cm

Using lens formula,

$$\frac{1}{v} - \frac{1}{u} = \frac{1}{f}$$

$$\frac{1}{v} - \frac{1}{-20} = \frac{1}{-10}$$

$$\frac{1}{v} = \frac{1}{-10} - \frac{1}{20}$$

$$\Rightarrow v = \frac{-20}{3} = -6.66 \text{ cm}$$

Negative sign implies that the image is formed on the same side as the object.

$$\text{We know that magnification, } m = \frac{v}{u} = \frac{-20/3}{-20} = \frac{1}{3}$$

Since magnification is positive, so image is virtual and erect.

Let  $h_i$  be the height of the image.

$$\text{We also know that: } m = \frac{v}{u} = \frac{h_i}{h_o}$$

$$\frac{1}{3} = \frac{h_i}{5}$$

$$h_i = \frac{5}{3} = 1.66 \text{ cm}$$

As  $h_i < h_o$

The image formed is smaller than the object.

**Marks: 3**

**Question 17.** Mention the types of mirrors used as (i) rear view mirrors, (ii) shaving mirrors. List two reasons to justify your answers in each case.

**Solution:** i. Rear view mirrors: Convex mirrors

Reason: (a) They produce virtual and erect images of the objects. (b) They have a wider field of view as they are curved outwards.

ii. Shaving mirrors: Concave mirrors

Reason: (a) Image formed is magnified so that the details of the object can be seen clearly. (b) Image formed is virtual and erect when the object is placed close to the mirror.

**Marks: 3**

**Question 18.** State the difference in colours of the Sun observed during sunrise/ sunset and noon. Give explanation for each.

**Solution:** During sunrise and sunset, Sun is red in colour while at noon, the Sun appears white.

At the time of sunrise and sunset, the Sun is near the horizon. The rays from the Sun have to travel a much larger part of the atmosphere to reach an observer on earth. So, most of the blue light gets scattered away. The red colour which has the largest wavelength is scattered the least and enters into our eyes. Hence, the Sun appears red at the time of sunrise and sunset.

At noon, the sun is nearly overhead. The sunlight has to pass through much smaller portion of the Earth's atmosphere. The scattering is much less and the Sun looks white.

**Marks: 3**

**Question 19.** (a) What is an ecosystem? List its two main components.

(b) We do not clean ponds or lakes, but an aquarium needs to be cleaned regularly. Explain.

**Solution:** Ecosystem is a self-sustaining system where the biotic and abiotic organisms of various Communities live with each other.

(a) The two components of the ecosystem are- Biotic and Abiotic. Biotic system consists of all the living organisms of particular area like humans, animals etc. and the nonliving component consists of air, minerals, soil, water and sunlight.

(b) Ponds are an example of a natural ecosystem whereas an aquarium is an example of an artificial ecosystem. Ponds do not need to be cleaned but aquarium needs to be cleaned because an aquarium does not contain soil and decomposing bacteria which helps in degrading complex organic substances into simple inorganic substances. But ponds or lakes have this ability of self-purification, and therefore these do not need to be cleaned.

**Marks: 3**

**Question 20.** (a) Write the function of placenta in females.

(b) List four ways of preventing pregnancy. State two advantages of using such preventive methods.

**Solution:** (a) Placenta is a disc like tissue which develops between the uterus wall and embryo.

Role of placenta:

i. Exchange of water between mother and the foetus.

ii. Exchange of nutrients.

- iii. Exchange of respiratory gases.
- iv. Excretion of nitrogenous wastes from foetus. Nitrogenous waste crosses the placenta and is removed by mother's kidney.
- v. Antibodies also cross the placenta and provide immunity to the baby.

(b) Ways of preventing pregnancy:

- i. Natural methods: In this method, sexual act is avoided from the 10<sup>th</sup> day to the 17<sup>th</sup> day of the menstrual cycle, since during this period ovulation is expected. Therefore, the chances of fertilisation are very high.
- ii. Barrier methods: In this method, the fertilisation of ovum and sperm is prevented with the help of physical devices such as condoms and diaphragm.
- iii. Oral contraceptives: In this method, tablets or drugs are taken orally. These contain small doses of hormones which prevent the release of eggs and prevent fertilisation.

**Marks: 5**

**Question 21.** (a) Identify A, B and C in the given diagram and write their functions.

(b) Mention the role of gamete and zygote in sexually reproducing organisms.

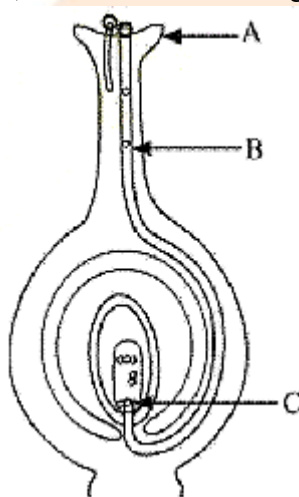

**Solution:** (a) A - Stigma.

Function - The stigma is a sticky surface where the pollen grains land and germinate.

B - Pollen tube.

Function - It carries the pollen grains to the egg cell for fertilisation.

C - Egg cell.

Function - It fuses with the male gamete and leads to the formation of the zygote.

(b) Role of gametes - Gametes play an important role in sexually reproducing organisms as they carry the entire genetic information of the organism. These gametes upon fusion result in the formation of the zygote, which develops into a new individual. Any deformation in the gametes will lead to deformity in the newly formed offspring.

Role of zygote - Zygote is the diploid cell formed by the fusion of male and female gametes during fertilisation in sexual reproduction. Zygote is the first stage in the development process of an organism and it contains all the genetic information of both the parents essential for the growth of the new organism.

**Marks: 5**

**Question 22.** (a) A person cannot read newspaper placed nearer than 50 cm from his eyes. Name the defect of vision he is suffering from. Draw a ray diagram to illustrate this defect. List its two possible causes. Draw a ray diagram to show how this defect may be corrected using a lens of appropriate focal length.



(b) We see advertisements for eye donation on television or in newspaper. Write the importance of such advertisements.

**Solution:** (a) The person is suffering from Hypermetropia i.e., far-sightedness. It is a defect of vision due to which a person cannot see nearby objects clearly though he can see distant objects clearly. In this defect the image of the nearby object is formed behind the retina of eye.

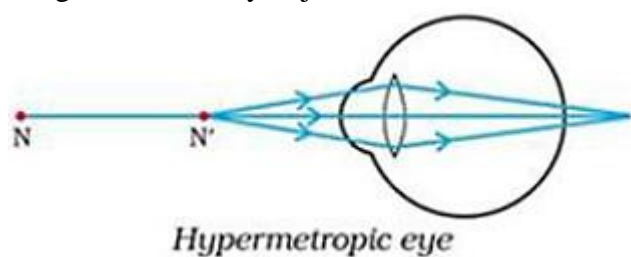

Hypermetropia is caused due to:

- i. decrease in length of the eyeball
- ii. increase in focal length of the eye lens

This defect can be corrected using a convex lens of appropriate focal length so that the image gets formed on the retina.

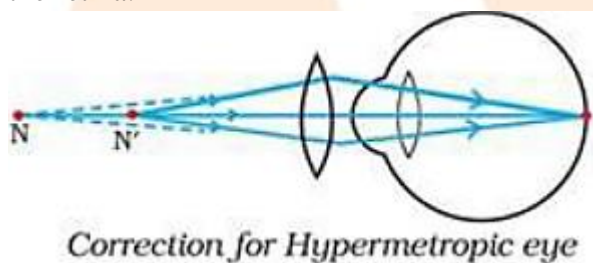

(b) Eye donations:

Our eyes can live even after our death, so by donating our eyes, we can give vision to a blind person and give them an opportunity to see the world. By giving such advertisements in newspapers, we can make more people aware for this noble cause and raise the number of eye donations for blind people.

**Marks: 5**

**Question 23.** State Snell's law of refraction of light. Write an expression to relate refractive index of a medium with speed of light in vacuum.

The refractive index of a medium 'a' with respect to medium 'b' is  $\frac{2}{3}$  and the refractive index of medium 'b' with respect to medium 'c' is  $\frac{4}{3}$ . Find the refractive index of medium 'c' with respect to medium 'a'.

**Solution:** Snell's law of refraction: The ratio of the sine of angle of incidence to the sine of angle of refraction is constant for a pair of media.

Mathematically, it can be given as follows:

When light travels from medium a to medium b, such that 'i' is the angle of incidence and 'r' is the angle of refraction, then

$$\frac{\sin i}{\sin r} = {}^a n_b$$

where,  ${}^a n_b$  is the relative refractive index of medium 'b' with respect to medium 'a'.

Relation between refractive index (n) of a medium and the speed of light in vacuum is:

$$n = \frac{\text{Speed of light in vacuum (c)}}{\text{Speed of light in medium (c)}}$$

Given that:

Refractive index of a with respect to b,  ${}^b n_a = \frac{n_a}{n_b} = \frac{2}{3}$  ..... (i)

Refractive index of b with respect to c,  ${}^c n_b = \frac{n_b}{n_c} = \frac{4}{3}$  ..... (ii)

$\therefore$  Refractive index of c with respect to a,  ${}^a n_c = \frac{n_c}{n_a} = \frac{n_c}{n_b} \times \frac{n_b}{n_a}$

${}^a n_c = \frac{3}{4} \times \frac{3}{2}$  ----- Using eq. (i) and (ii)

${}^a n_c = \frac{9}{8}$

**Marks: 5**

**Question 24.** (a) Define the term 'isomers'

(b) Draw two possible isomers of the compound with molecular formula  $C_3H_6O$  and write their names.

(c) Give the electron dot structures of the above two compounds.

**Solution:** (a) Compounds having same molecular formula but different structural formula are known as isomers.

(b) Two possible isomers of the compound with molecular formula  $C_3H_6O$ :

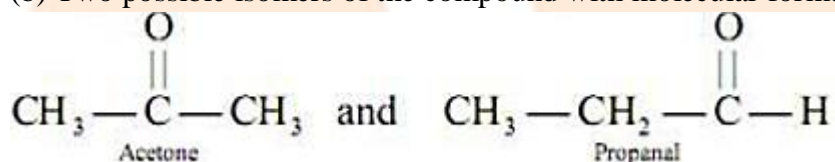

(c) Electron dot structure:

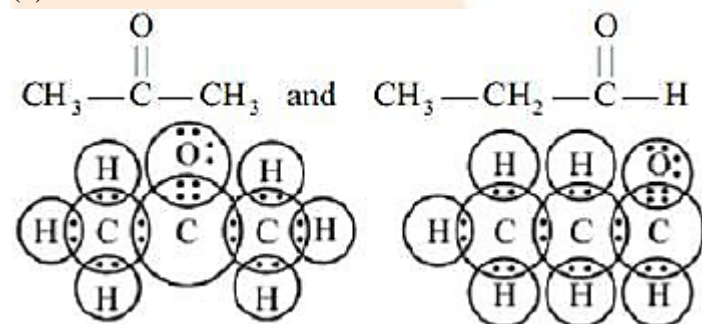

**Marks: 5**

## SECTION B

**Question 25.** A student obtained a sharp image of a burning candle, placed at the farther end of a laboratory table, on a screen using a concave mirror. For getting a better value of focal length of the mirror, what should the student do?

- He should move the mirror away from the screen.
- He should move the mirror slightly towards the screen.
- He should move the mirror as well as the screen towards the newly selected object.
- He should move only the screen towards the newly selected object.

**Solution:** (b) He should move the mirror slightly towards the screen.

When an object is at infinity, image is formed at the focus and when an object is beyond C then image is formed between C and F. As the object is farther, image will be closer to F. So, the student should move the mirror slightly towards the screen.

**Marks: 1**

**Question 26.** A student focused the image of a distant object using a device 'X' on a white screen 'S' as shown in the figure. If the distance of the screen from the device is 40 cm, select the correct statement about the device.

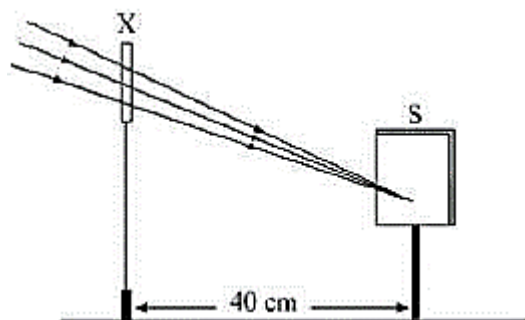

- (a) The device X is a convex lens of focal length 20 cm.
- (b) The device X is a concave mirror of focal length 40 cm.
- (c) The device X is a convex mirror of radius of curvature 40 cm.
- (d) The device X is a convex lens of focal length 40 cm.

**Solution:** (d) The device X is a convex lens of focal length 40 cm.

The parallel rays from the distant object fall on the convex lens and converge at its second principal focus (i.e., where the screen is placed). Then the distance between the screen and the convex lens gives the approximate focal length of the lens i.e., 40 cm.

**Marks: 1**

**Question 27.** Study the following ray diagrams:

I.

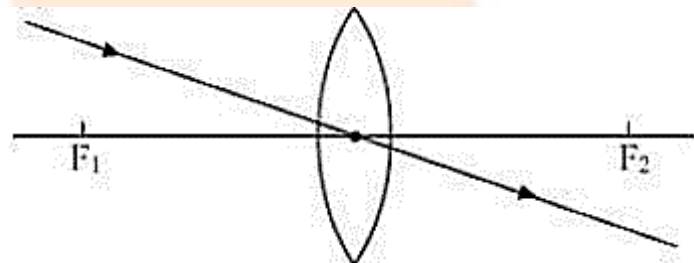

II.

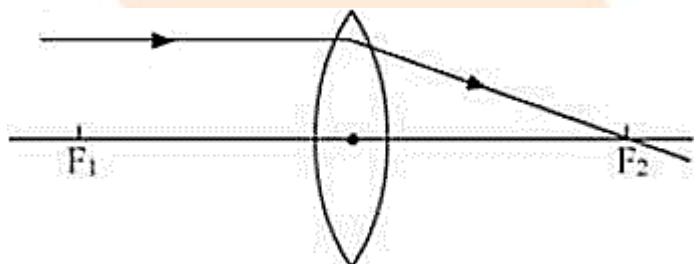

III.

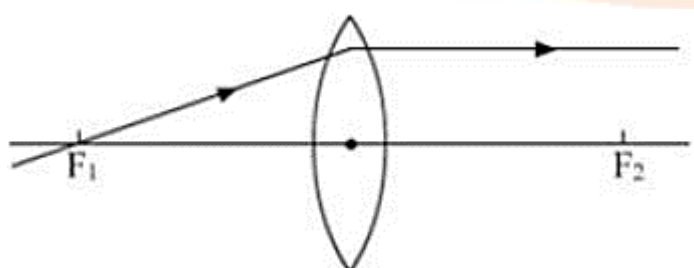

IV.

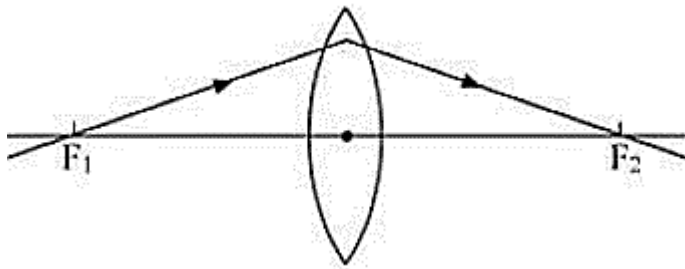

The diagrams showing the correct path of the ray after passing through the lens are:

- (a) II and III only
- (b) I and II only
- (c) I, II and III
- (d) I, II and IV

**Solution:** (c) Ray diagrams I, II and III are correct.

The light ray passing through the optical centre of the lens does not deviate. The light ray parallel to the principal axis passes through the second focus of the lens. The light ray passing through the first focus becomes parallel to the principal axis after passing through the lens.

**Marks: 1**

**Question 28.** Out of the five incident rays shown in the figure find the three rays which are obeying the laws of refraction and may be used for locating the position of the image formed by a convex lens:

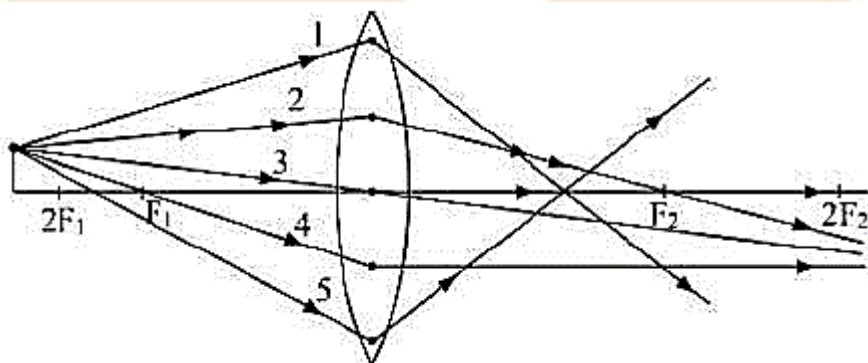

- (a) 1, 2 and 3
- (b) 2, 3 and 4
- (c) 3, 4 and 5
- (d) 1, 2 and 4

**Solution:** (b) Rays 2, 3 and 4 obey the laws of refraction.

Ray (2) is parallel to the principal axis and passes through the second focus of the lens.

Ray (3) passes through the optical centre and does not deviate.

Ray (4) passes through the first focus of the lens and goes parallel to the principal axis.

**Marks: 1**

**Question 29.** Select from the following the best set-up for tracing the path of a ray of light through a rectangular glass slab:

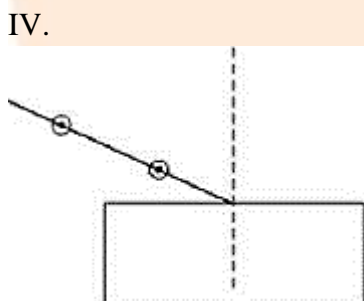
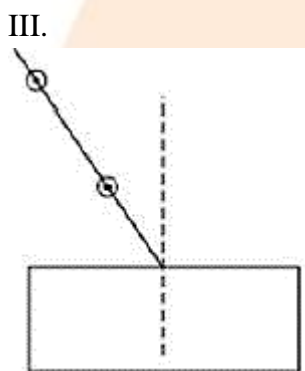
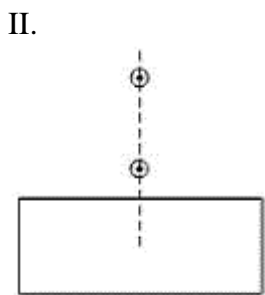
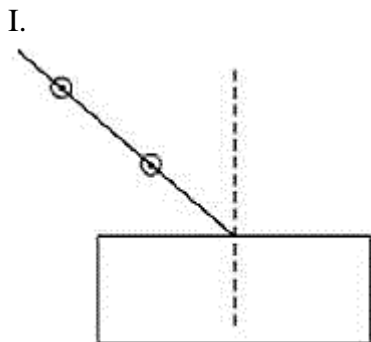

- (a) I
- (b) II
- (c) III
- (d) IV

**Solution:** (a) I

The best set up is given in figure I. The incoming light should not fall perpendicularly as the light will emerge straight and refraction cannot be traced. The light rays should not be very close or far from the normal as the emergent rays are difficult to trace.

**Marks: 1**

**Question 30.** After tracing the path of rays of light through a glass slab for three different angles of incidence, a student measured the corresponding values of angle of refraction 'r' and angle of emergence 'e' and recorded them in the table given below:

S. No	$\angle i$	$\angle r$	$\angle e$
I	$30^\circ$	$20^\circ$	$31^\circ$
II	$40^\circ$	$25^\circ$	$40^\circ$
III	$50^\circ$	$31^\circ$	$49^\circ$

The correct observations are:

- (a) I and II
- (b) II and III
- (c) I and III
- (d) I, II and III

**Solution:** (d) I, II and III

For light rays passing through a glass slab, the following conditions should hold true:

1.  $\angle i \approx \angle e$  and  $\angle r < \angle i$
2. Also, with the increase in incident angle, the refracted angle also increases.

Both of these conditions are satisfied in all the three observations.

**Marks: 1**

**Question 31.** In an experiment to trace the path of a ray of light through a glass prism for different values of angle of incidence a student would find that the emergent ray:

- (a) is parallel to the incident ray
- (b) perpendicular to the incident ray
- (c) is parallel to the refracted ray
- (d) bends at an angle to the direction of the incident ray

**Solution:** (d) bends at an angle to the direction of incident ray

As the light gets refracted twice at different angles the emergent ray bends at an angle to the direction of incident ray.

**Marks: 1**

**Question 32.** While performing an experiment to trace the path of a ray of light passing through a glass prism, four students marked the incident ray and the emergent ray in their diagrams in the manner shown below. Which one is correct?

I.

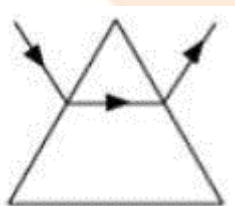

II.

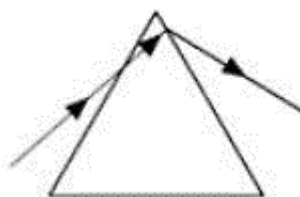

III.

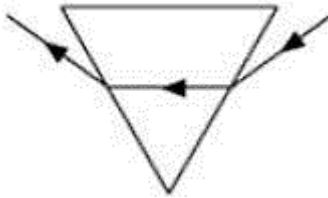

IV.

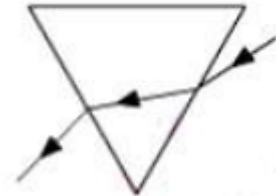

- (a) I
- (b) II
- (c) III
- (d) IV

**Solution:** (c) III

When light goes from a rarer medium to a denser medium; it bends towards the normal and vice-versa. This condition is fulfilled in figure (III).

**Marks: 1**

**Question 33.** Study the different conclusions drawn by students of a class on the basis of observations of preserved/available specimens of plants and animals.

- I. Potato and sweet potato are analogous organs in plants and animals.
- II. Wings of insects and wings of birds are homologous organs in animals.
- III. Wings of insects and wings of bats are analogous organs in animals.
- IV. Thorns of citrus and tendrils of cucurbita are analogous organs in plants

The correct conclusions are:

- (a) I and II
- (b) II and IV
- (c) III and IV
- (d) I and III

**Solution:** (a) I and II

Analogous organs are those which do not share a common ancestry but perform common functions. Hence, wings of insects and wings of bats are analogous organs in animals and potato and sweet potato are analogous organs in plants.

**Marks: 1**

**Question 34.** You have potato, carrot, radish, sweet potato, tomato and ginger bought from the market in your jute bag. Identify two vegetables to represent the correct homologous structures.

- (a) Potato and sweet potato
- (b) Carrot and tomato
- (c) Potato and tomato
- (d) Carrot and radish

**Solution:** (d) Carrot and Radish

Homologous structures are similar in origin but perform different functions. Carrot and radish are underground roots. So, they are considered homologous structures.

**Marks: 1**

**Question 35.** In the figure, the parts marked A, B and C are sequentially:

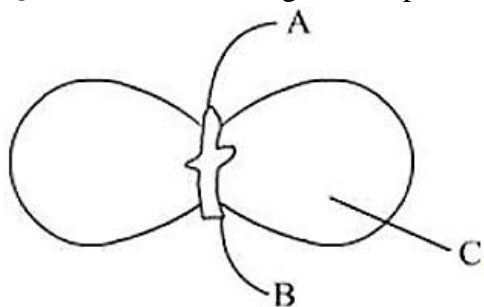

- (a) Plumule, Cotyledon and Radicle
- (b) Radicle, Cotyledon and Plumule
- (c) Radicle, Plumule and Cotyledon
- (d) Plumule, Radicle and Cotyledon

**Solution:** (d) Plumule, Radicle and Cotyledon

In the figure, the part marked A is Plumule, B is Radicle and C is Cotyledon.

**Marks: 1**

**Question 36.** Select the correct statements for the process of budding in yeast:

- I. A bud arises from a particular region on a parent body.
- II. A parent cell divides into two daughter cells; here the parental identity is lost.
- III. Before detaching from the parent body a bud may form another bud.
- IV. A bud when detached from the parent body grows into a new individual.

- (a) II, III and IV
- (b) I, II and III
- (c) III, IV and I
- (d) None of the above

**Solution:** (d) None of the above

Yeast reproduces asexually by the process of budding.

Budding is a type of asexual reproduction in which a new organism is formed from a bud of an existing organism. A small bud is formed at a specific position on the parent cell. The nucleus of parent cell splits and a part of it enters inside the newly formed bud. The bud develops into a new cell or daughter organism. The new organism remains attached to the parent organism till it matures. After attaining maturity it separates from the parent body.

**Marks: 1**

**Question 37.** A student after observing a slide showing different stages of binary fission in Amoeba draws the following diagrams. However these diagrams are not in proper sequence.





The correct sequence is:

- (a) I, V, IV, III, II
- (b) I, V, III, IV, II
- (c) I, III, IV, V, II
- (d) None of these

**Solution:** (d) None of these

The correct procedure in reproduction in Amoeba is,

- (a) Chromosome is replicated.
- (b) Chromosome splits into daughter strands.
- (c) Cytokinesis splits the Amoeba into two daughter cells.
- (d) Two Amoebae with identical DNA.

**Marks: 1**

**Question 38.** Read the following statements:

I. When a red litmus paper is dipped into the reaction mixture of a saponification reaction, it turns blue and the reaction is exothermic.

II. When a blue litmus paper is dipped into the reaction mixture of a saponification reaction, its colour does not change and the reaction is exothermic.

III. When a red litmus paper is dipped into the reaction mixture of a saponification reaction, its colour does not change and the reaction is endothermic.

IV. When a blue litmus paper is dipped into the reaction mixture of a saponification reaction, its colour does not change and the reaction is endothermic.

Which of the above statements are correct?

- (a) I and II
- (b) II and III
- (c) III and IV
- (d) I and IV

**Solution:** (a) I and II

Soap solution is basic in nature because it is formed from a strong base NaOH. Hence it turns red litmus paper blue and does not change the color of blue litmus paper. The saponification reaction is exothermic in nature. The correct statements are I and II.

**Marks: 1**

**Question 39.** A student prepared 20% sodium hydroxide solution in a beaker containing water. The observations noted by him are given below.

I. Sodium hydroxide is in the form of pellets.

II. It dissolves in water readily.

III. The beaker appears cold when touched from outside.

IV. Red litmus paper turns blue when dipped into the solution.

The correct observations are:

- (a) I, II, and III
- (b) II, III and IV
- (c) III, IV and I
- (d) I, II and IV

**Solution:** (d) I, II and IV

Sodium hydroxide is in the form of small white pellets and is soluble in water. Being basic in nature, it turns red litmus paper blue. The correct observation is I, II and IV.

**Marks: 1**

**Question 40.** Hard water required for an experiment is not available in a school laboratory. However, following salts are available in the laboratory. Select the salts which may be dissolved in water to make it hard for the experiment.

1. Calcium Sulphate
2. Sodium Sulphate
3. Calcium Chloride
4. Potassium Sulphate
5. Sodium Hydrogen Carbonate
6. Magnesium Chloride

- (a) 1, 2 and 4  
(b) 1, 3 and 6  
(c) 3, 5 and 6  
(d) 2, 4 and 5

**Solution:** (b) 1, 3 and 6

Hard water contains  $\text{Ca}^{2+}$  and  $\text{Mg}^{2+}$  ions. Thus the salts which can be added to water to make it hard are calcium sulphate, calcium chloride and magnesium chloride i.e., the salts 1, 3 and 6.

**Marks: 1**

**Question 41.** In an experiment to study the properties of acetic acid, a student takes about 2 ml of acetic acid in a dry test tube. He adds about 2 ml of water to it and shakes the test tube well. He is likely to observe that:

- (a) The acetic acid dissolves readily in water.  
(b) The solution becomes light orange.  
(c) Water floats over the surface of acetic acid.  
(d) Acetic acid floats over the surface of water.

**Solution:** (a) The acetic acid dissolves readily in water.

The acetic acid dissolves readily in water to form a clear solution.

**Marks: 1**

**Question 42.** A student takes 2 ml acetic acid in a dry test tube and adds a pinch of sodium hydrogen carbonate to it. He makes the following observations:

- I. A colourless and odourless gas evolves with a brisk effervescence.
- II. The gas turns lime water milky when passed through it.
- III. The gas burns with an explosion when a burning splinter is brought near it.
- IV. The gas extinguishes the burning splinter which is brought near it.

The correct observations are:

- (a) I, II and III  
(b) II, III and IV  
(c) III, IV and I  
(d) IV, I and II

**Solution:** (d) IV, I and II

When acetic acid is taken in a dry test tube and sodium hydrogen carbonate is added to it, a colourless and odourless gas evolves with a brisk effervescence i.e., CO<sub>2</sub>.

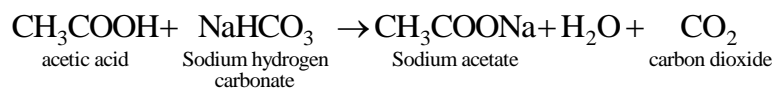

When CO<sub>2</sub> is passed through lime water, it turns lime water milky because of formation of calcium carbonate ppt.

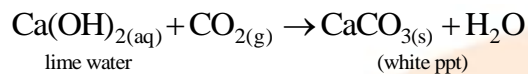

CO<sub>2</sub> being a non-supporter of combustion extinguishes the burning splinter when it is brought near it. So, the correct observations are IV, I and II.

**Marks: 1**